

alcohol complexes investigated with X-rays in this study have structures depending more on the number of hydrocarbon chain branches of the alcohols than on the branch lengths. Apparently the starch helix enlarges to accommodate the more bushy branched-chain alcohols. Correspondingly the unit cell becomes larger, as is evidenced by the general displacement of the diffractions to lower diffraction angles. Unfortunately, the pattern of the branched-chain alcohol precipitates becomes definitely non-hexagonal, which makes it impossible to determine the changes in helix dimensions quantitatively from powder patterns alone. It can be shown, however, that with the spacings observed (up to 20 Å.) it is possible to construct helix models which are able to include the branched-chain alcohols.

That helix cross section and packing does not change greatly on removing the alcohol was shown by Rundle and Edwards³ for the *n*-butanol complex. Similar effects can be inferred for the present cases, in which the linear or branched alcohols leave their imprints behind after being driven off by heat. The simplest hypothesis to account for these facts is one postulating an internal absorption of the alcohol molecules, since otherwise the structures might be expected to collapse to the same condition in every case on removing the alcohol and/or to show some relation to the hydrocarbon chain lengths.

That the seven alcohols considered in these experiments yield only two different dry solids from starch is preliminary evidence that the amylose chain can coil only in a limited number of ways. The realizable configurations, possibly possessing various numbers of residues per turn, plus other variations, can be discovered by X-ray examination of the many complexes formed by association of organic substances with amyloses.

The author gratefully acknowledges the financial assistance of the Corn Industries Research Foundation in this work.

DEPARTMENT OF BIOLOGY AND BIOLOGICAL ENGINEERING
MASSACHUSETTS INSTITUTE OF TECHNOLOGY
CAMBRIDGE, MASSACHUSETTS

RECEIVED SEPTEMBER 19, 1944

Vapor Phase Hydrogenation of Naphthalene and Tetralin over Nickel Catalyst

BY W. J. CERVENY AND B. B. CORSON

Sabatier and Senderens¹ reported in 1901 that tetralin was the only product when naphthalene was hydrogenated in vapor phase over nickel. Lush² confirmed this work in 1927, reporting that neither naphthalene nor tetralin could be hydrogenated to decalin in vapor phase, and presenting an explanation why vapor phase hydrogenation gave only tetralin whereas liquid phase hydro-

(1) Sabatier and Senderens, *Compt. rend.*, **132**, 1254 (1901).
(2) Lush, *J. Soc. Chem. Ind.*, **46**, 454T (1927); British Patent, 304,403, Jan. 24, 1929.

genation gave decalin. However, in 1904, Leroux³ reported that he repeated the experiments of Sabatier and Senderens and found that tetralin was easily hydrogenated to decalin. In 1938, Smith, Rall, and Grandone⁴ also concluded that decalin could be produced in vapor phase from naphthalene.

Because of these contradictions and because we considered this alleged selectivity unlikely, we studied the vapor phase hydrogenation of naphthalene and tetralin over nickel and found that decalin was readily obtained.

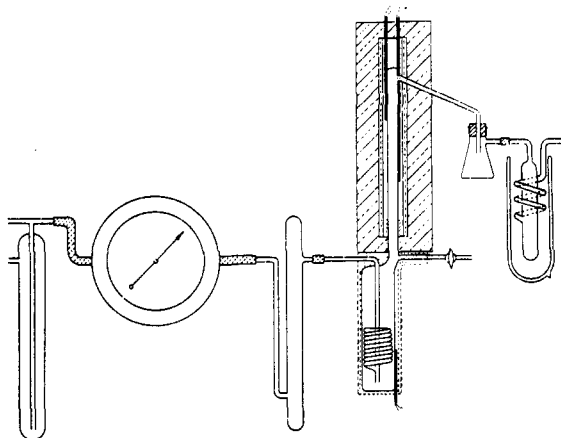

Fig. 1.—Apparatus for vapor phase hydrogenation.

The apparatus (Fig. 1) was constructed of glass and consisted of a vaporizer⁵ sealed to a vertical (14 mm. i. d.) catalyst tube. A known volume of dry hydrogen was passed through the heated vaporizer ($\approx 110^\circ$ for naphthalene, $\approx 114^\circ$ for tetralin) whence the gas mixture passed upward through a 6-inch section of catalyst tube packed with 3 inches of glass wool followed by 3 inches of glass pearls, and finally through a 2.5-inch catalyst bed and out the exit arm. The entire length of the catalyst tube was at a uniform temperature which was always higher than the temperature of the entering gas. The low partial pressure of the hydrocarbon in the gas mixture and the operation of the catalytic unit guaranteed true vapor phase conditions during hydrogenation. The catalyst was in the form of $1/8" \times 1/8"$ pills containing about 65% of nickel and 35% of diatomaceous earth;⁶ the catalyst was reduced by hydrogen at 425° before use. After the naphthalene runs had been made, the apparatus was dismantled and cleaned, and a new catalyst bed was charged for the tetralin runs. Hydrogenation was run for two hours at each set of conditions to attain steady state before collecting product.

The naphthalene feed (Koppers Company, Chemical Grade) was desulfurized by sodium;⁷ the desulfurized product froze at 80.2° (cooling curve) and contained 0.001% of sulfur. The tetralin feed was twice distilled at 50 mm. through a 3-foot Fenske column with 15/1 reflux at the start and 7/1 on the plateau, the middle 75% of the plateau being taken; f. p. -35.9° (cooling curve), b. p. 207.2° (760 mm.), n_{20}^D 1.5412, d_{20}^{20} 0.971, sulfur 0.001%. According to Rossini and Mair⁸ the constants

(3) Leroux, *Compt. rend.*, **139**, 672 (1904).
(4) Smith, Rall and Grandone, U. S. Bureau of Mines, Tech. Paper No. 587 (1938).
(5) Corson, *Ind. Eng. Chem., Anal. Ed.*, **10**, 646 (1938).
(6) Ipatieff and Corson, *Ind. Eng. Chem.*, **30**, 1039 (1938).
(7) Schroeter, U. S. Patent 1,763,410 (1930).
(8) Rossini and Mair, *Refiner Natural Gasoline Mfr.*, **20**, 494 (1941).

of tetralin are: f. p. -35.80° ; b. p. (760 mm.) 207.57° ; n_{D}^{20} 1.54135; d_{4}^{20} 0.9702.

Both naphthalene and tetralin were completely hydrogenated to decalin under all the conditions tried (Tables I and II). The liquid catalyzate gave no temperature rise when 2 cc. of it was shaken for three minutes in a test-tube with 2 cc. of nitrating mixture (1 vol. sulfuric acid d. 1.84 plus 2 vols. nitric acid d. 1.42), this qualitative test showing the absence of more than 3% of naphthalene or tetralin. The physical constants (n_{D}^{20} , d_{4}^{20} , δ (specific dispersion)⁹) of the catalyzates agreed with those of mixtures of *cis*- and *trans*-decalin.¹⁰ The catalyzate composite boiled at $187.1-194.1^{\circ}$ at 760 mm.

TABLE I

VAPOR PHASE HYDROGENATION OF NAPHTHALENE OVER NICKEL CATALYST

Hrs.	Pressure, mm.	Inlet H ₂ 1./- hr./- 25°C.	Mole ratio H ₂ /C ₁₀ H ₈	Catalyst temp., °C.	g.	Liquid catalyzate		
						n_{D}^{20}	d_{4}^{20}	δ
15	755	1.4	26.0	123	3.7	1.4735	0.880	97
16	741	1.7	25.5	149	5.6	1.4729	.878	98
16	740	1.7	24.5	176	5.6	1.4732	.879	98
16	740	1.7	24.5	199	5.3	1.4719	.876	97

TABLE II

VAPOR PHASE HYDROGENATION OF TETRALIN OVER NICKEL CATALYST

Hrs.	Pressure, mm.	Inlet H ₂ 1./- hr./- 25°C.	Mole ratio H ₂ /C ₁₀ H ₈	Catalyst temp., °C.	g.	Liquid catalyzate		
						n_{D}^{20}	d_{4}^{20}	δ
3	735	5.2	14.6	126	4.9	1.4740	0.881	98
3	735	5.1	14.6	151	5.4	1.4749	.883	98
3	735	4.8	14.6	175	4.7	1.4740	.881	98
3	735	5.2	14.6	200	5.1	1.4792	.892	98

(9) $\delta = (nF - nC)/d \times 10^4$.

(10) Seyer and Walker (THIS JOURNAL, 60, 2125 (1938)) reported d_{4}^{20} 0.8963 and 0.8699, b. p. (760 mm.) 194.6 and 185.5 and n_{D}^{20} 1.48113 and 1.46968 for *cis*- and *trans*-decalins, respectively. The specific dispersion of decalin mixtures has been reported as about 98 (Ward and Fulweiler, *Ind. Eng. Chem., Anal. Ed.*, 6, 396 (1934); Fuchs and Anderson, *Ind. Eng. Chem.*, 29, 319 (1937); Ward and Kurtz, *Ind. Eng. Chem., Anal. Ed.*, 10, 559 (1938); Grosse and Wackher, *ibid.*, 11, 614 (1939); Bloch and Thomas, THIS JOURNAL, 66, 1589 (1944)).

KOPPERS MULTIPLE FELLOWSHIP ON TAR SYNTHETICS
MELLON INSTITUTE OF INDUSTRIAL RESEARCH
PITTSBURGH, PENN. RECEIVED SEPTEMBER 2, 1944

The Reduction of Diphenylnitrosamine in the Presence of Raney Nickel Catalyst and Platinum Catalyst¹

BY GERALD F. GRILLOT

Paal and Yao² published in 1930 the results that they had obtained in reducing diphenylnitrosamine with hydrogen at about one atmosphere pressure and at room temperature in the presence of palladium deposited on calcium carbonate and barium sulfate. They had expected to obtain *unsym*-diphenylhydrazine, but instead diphenylamine and nitrogen were formed almost quantitatively.

(1) Original manuscript received June 21, 1944.

(2) Paal and Yao, *Ber.*, 63B, 57 (1930).

In the hope that *unsym*-diphenylhydrazine might nevertheless be obtained by the use of a suitable catalyst, the author carried out the reduction using as catalyst both Raney nickel³ and Adams platinum oxide.⁴

Thus, using diphenylnitrosamine prepared according to the method of Fischer,⁵ melting after recrystallization at 66.5° as given by Witt,⁶ reduction with hydrogen in the presence of Raney nickel catalyst at 35 lb. pressure in alcoholic solution at room temperature was substantially complete in an hour, 89% of the theoretical quantity of hydrogen was absorbed and an 83% yield of crude diphenylamine, melting at 53° , was obtained. The odor of ammonia was quite evident in the reduced solution. The benzoyl derivative of the diphenylamine was prepared and it melted at 179° as compared with the recognized melting point of 180° .⁷ The mother liquor from the crystallization of the diphenylamine, with the addition of a few drops of acetic acid, gave no precipitate with benzaldehyde, indicating the absence of any *unsym*-diphenylhydrazine.

Using a somewhat more dilute solution containing in addition 5% of acetic acid by volume, four hours was required for the completion of the reaction, 85% of the theoretical amount of hydrogen was absorbed. Treatment of the solution with sodium hydroxide yielded ammonia equivalent to a 92% reduction.

Similar results were obtained using Adams platinum oxide catalyst in a slightly more dilute alcoholic solution.

These results confirmed the findings of Paal and Yao above mentioned, except that under our conditions a substantially quantitative yield of ammonia rather than of nitrogen resulted from the reduction.

(3) Adkins, "Reactions of Hydrogen, etc.," University of Wisconsin Press, Madison, Wis., 1937, p. 20.

(4) Gilman, "Organic Syntheses," Coll. Vol. 1, John Wiley and Sons, Inc., New York, N. Y., 1932, p. 452.

(5) Emil Fischer, *Ann.*, 190, 174 (1878).

(6) Witt, *Ber.*, 8, 856 (1875).

(7) Shriner and Fuson, "Identification of Organic Compounds," Sec. Ed., John Wiley and Sons, Inc., New York, N. Y., 1940, p. 196.

UNIVERSITY OF KENTUCKY

LEXINGTON, KY.

RECEIVED NOVEMBER 3, 1944

Interaction between Sodium Triphosphate and Salts of Polyvalent Cations as Shown by pH Measurements

BY LEA FRANKENTHAL

In the course of an investigation on sodium triphosphate an instantaneous acid shift was detected in solutions of this compound to which Mg^{++} , Ca^{++} , Mn^{++} or Al^{+++} salts were added. A similar qualitative observation of the decrease in pH has been made by H. Rudy¹ in a study of the dissolving effect of sodium triphosphate on calcium soaps. Accepted concepts concerning the

(1) H. Rudy, *Angew. Chem.*, 54, 447 (1941).